

PRODUCT CONSTRUCTION EXAMPLE

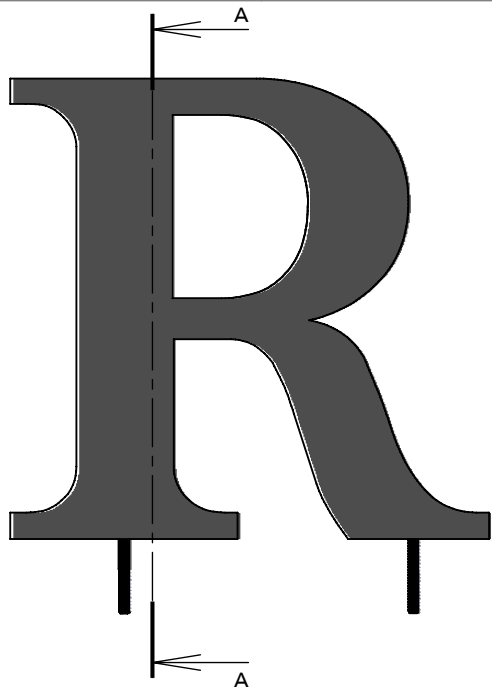

FRONT VIEW II SCALE 1 : 5

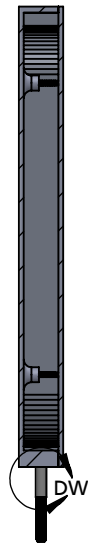

SECTION A-A II SCALE 1 : 5

NOTE: Styles with thin strokes or small letters may be cast solid

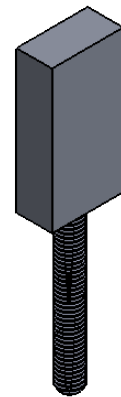

Standard returns bead blasted

0 - 7° return draft - thickness/depth - varies by style and height

Threaded studs

Letter finish varies

Tie back boss (see note)

Countersunk holes

Back secured to casting with flat head machine screws

Brushed or painted finish

1/8" thick back- typical

ISOMETRIC BACK VIEW II SCALE 1 : 3

Optional spacer sleeve (size varies)

Stainless steel stud (type and size varies)

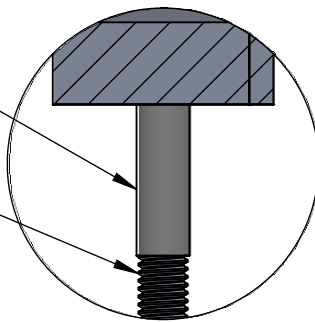

DETAIL DW II SCALE 1 : 1

NOTES:

- Letters 4 - 24", Minimum 3/8" thick
- Tie back required (not supplied) on letters >8" high
- Typical stud length 3 - 4" beyond bottom of letter
- Round letters (O, C, G, J, Q, S, U) sanded flat on bottom- optional
- Minimum of 2 studs per letter - typical
- 3/8 - 1/2" deep, 4 - 6" high, 10-24 stainless steel studs
- Over 1/2" deep, or over 6" high, 1/4-20 stainless steel studs - typical
- Standard font styles or customer per vector art. Flat faced/round/prismatic profile options. Typical 3/16 - 1/4" wall thickness on hollow back letters/logos.
- Letters or logos, standard or custom



TITLE:

CAST METAL BOTTOM STUD MOUNT - THICK BACK

MATERIAL:

ALUMINUM

PRODUCT TYPE:

CAST METAL

DWG NO. CAST 110

REV. 03.23.22

SCALE: AS INDICATED

SHEET 1 OF 1