

FRONT VIEW II SCALE 1:5

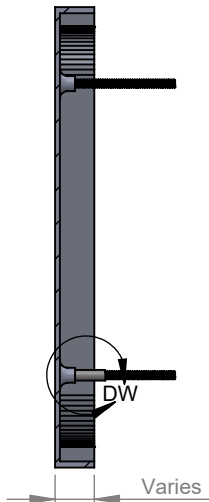

SECTION VIEW A-A II SCALE 1:5

NOTE: Styles with thin strokes or small letters may be cast solid

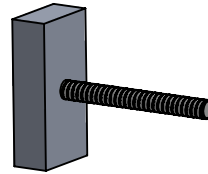

Standard returns
Bead blasted

Letter finish varies

Threaded studs

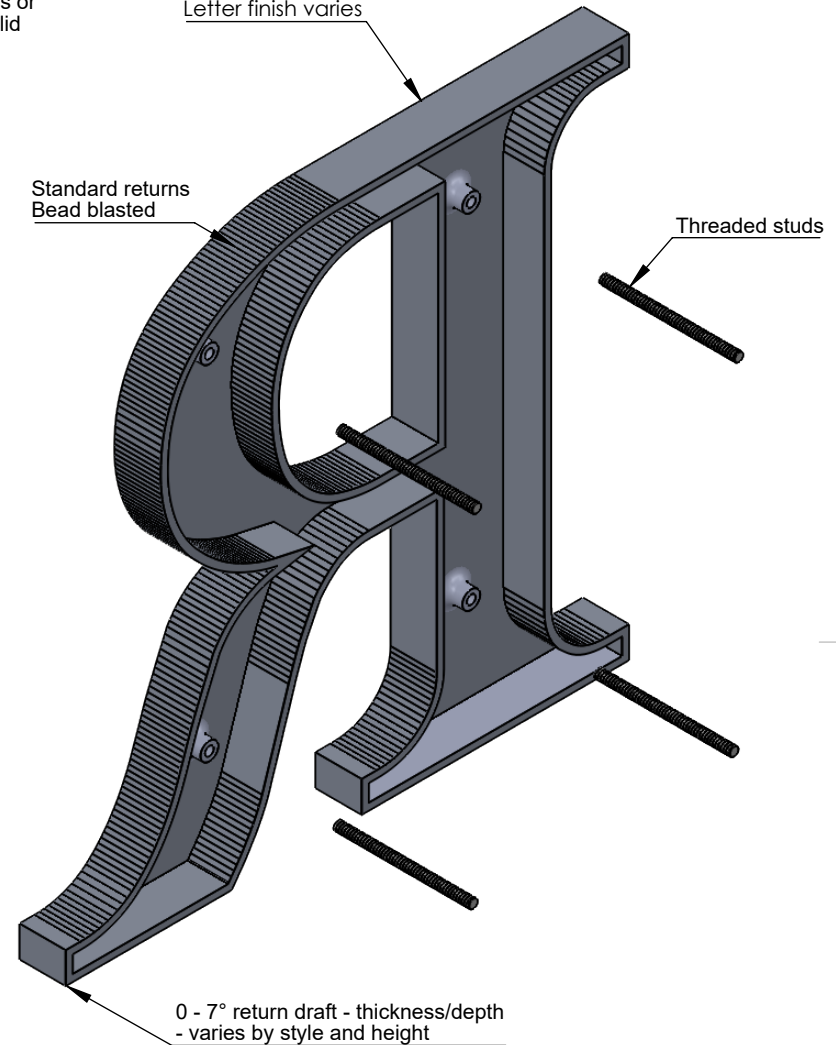

ISOMETRIC BACK VIEW II SCALE 1:3

Stud Boss (size varies)

Optional spacer sleeve
(Size varies)

Aluminum stud w/aluminum letter
Stainless steel stud w/bronze letter
(type and size varies)

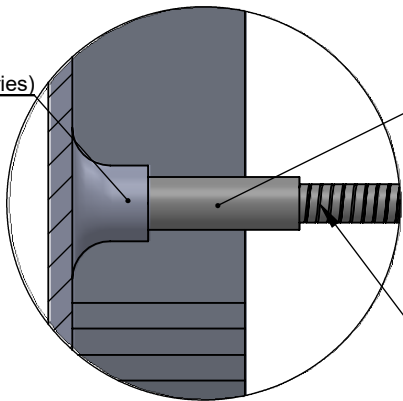

DETAIL DW II SCALE 1:1

SIZE	MIN STUDS/LTR
Up to 3"	3 studs
over 3" - 15"	4 studs
Over 15"	6 studs
Punctuation	2 studs

NOTES:

- Typical stud length 2" beyond back of letter-
- Letters under 15" high - 10/24 studs, 15"+ high - 1/4-20 studs.
- Less than 3/8" stroke, 6-32 or 4-40 studs
- Standard cast studs are in line for brick mortar (2-5/8" on center for mortar)
- Standard catalog styles or customer per vector art. Flat faced/round/prismatic profile options. Typical 3/16" - 1/4" wall thickness on hollow back letters/logos.
- Letters or logos, standard or custom



TITLE:

CAST METAL STUD MOUNT

MATERIAL: **ALUMINUM OR BRONZE**

PRODUCT TYPE: **CAST METAL**

DWG NO. CAST10

REV 03.23.22

SCALE: AS INDICATED

SHEET 1 OF 1