

FRONT VIEW SCALE 1 : 6

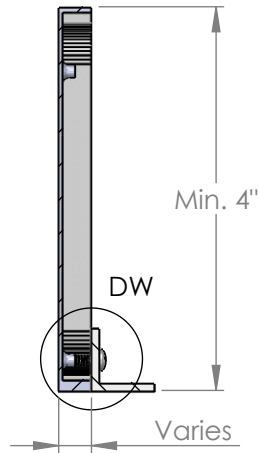

SECTION A-A SCALE 1 : 6

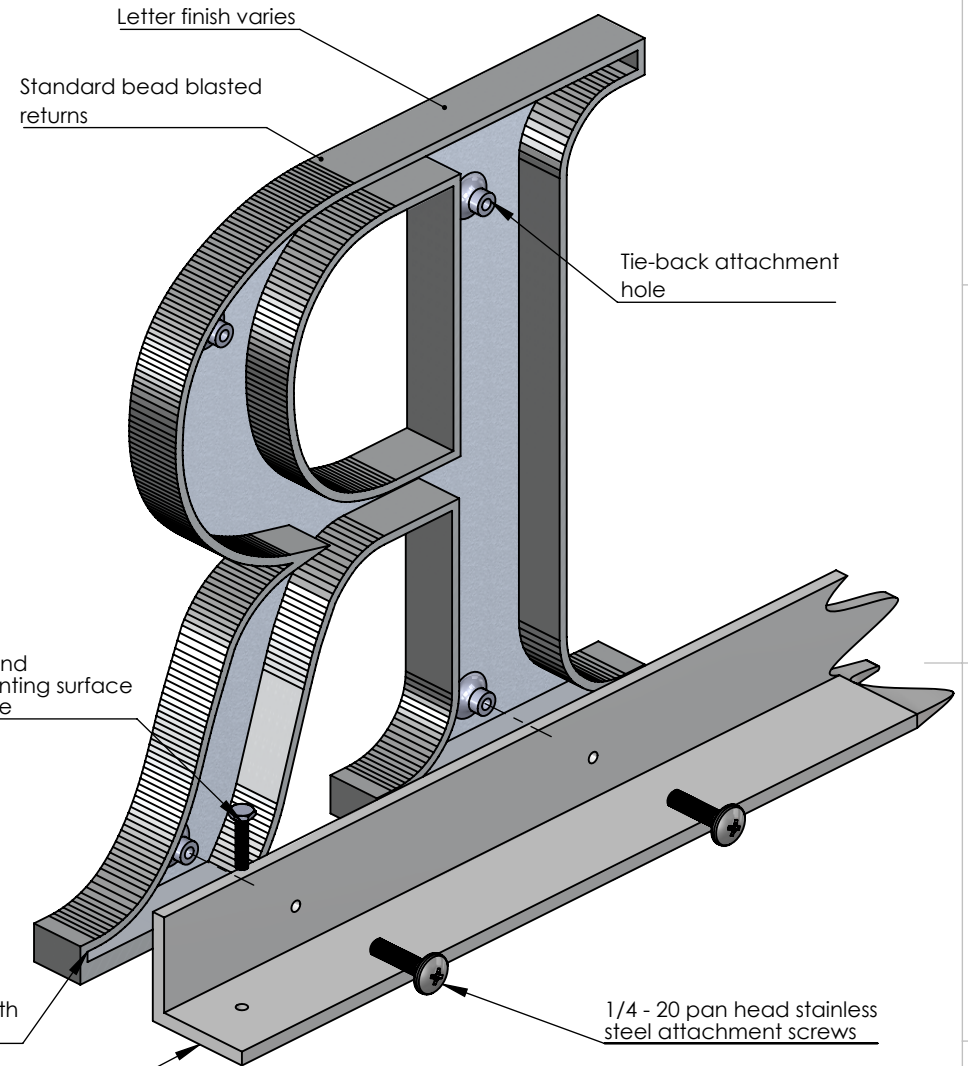

ISOMETRIC BACK VIEW II SCALE 1:3

Stud boss (size varies)

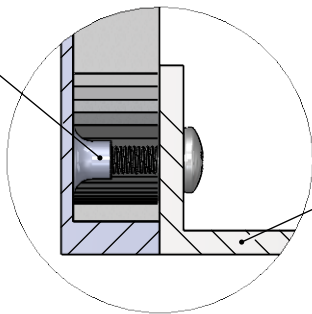

DETAIL DW SCALE 1 : 2

90 degree angle
6061-T6 extruded-aluminum

Customer supplied hardware and holes - for mounting rail to mounting surface
Type varies by mounting surface

0 - 7" return draft - thickness/depth
- varies by style and height

Customer supplied mounting hole & hardware for all rail mounts

NOTES:

- Letters are pre-assembled to rails to ensure fit. Min. 2 screws per letter - Larger letters shipped loose.
- Min. 4" - 30" high letters, min. 3/8" thick, min. 1/2 stroke
- Optional rail lengths, up to 96", typically mounted by word
- Round letter bottoms - sanded flat - optional
- Rail finish: painted standard or custom color
- Tie-backs recommended on letters over 12" high (not supplied)
- Optional angle brackets: 2" x 2" x 1/4", 1 1/2" x 1 1/2" x 3/16", 1" x 1" x 3/16"
- Standard catalog styles or customer per vector art. Flat faced/round/prismatic profile options. Typical 3/16" - 1/4" wall thickness on hollow back letters/logos.
- Letters or logos, standard or custom



TITLE:

CAST METAL BOTTOM ANGLE BRACKET MOUNT

MATERIAL:

ALUMINUM

PRODUCT TYPE:

CAST METAL