

FRONT VIEW II SCALE 1:2.5

SECTION VIEW A-A II SCALE 1:2.5

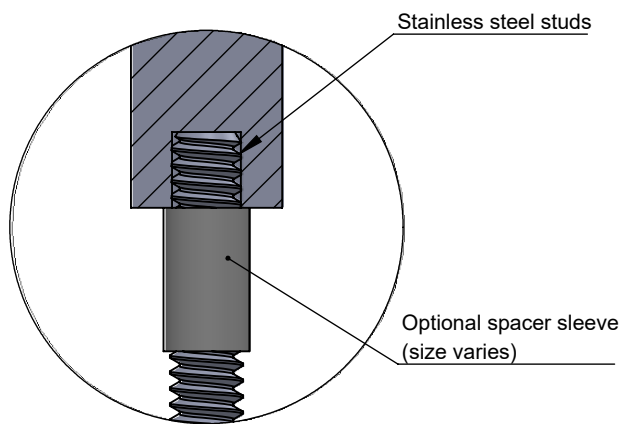

DETAIL DW II SCALE 2:1

- NOTES:**
- 4"-24" high letters
 - Typical stud length 2" beyond bottom of letter
 - Letters under 8" high - 10/24 studs, 8"+ high and 1/2" thick - 1/4-20 stainless steel studs.
 - Round letters (O, C, G, J, Q, S, U) sanded flat on bottom
 - Minimum 2 studs per letter, min. 3/8" thick
 - Backs will be unfinished, finished/painted optional
 - Tie back recommended if over 8" high letters (not included)
 - Letters or logos, standard or custom

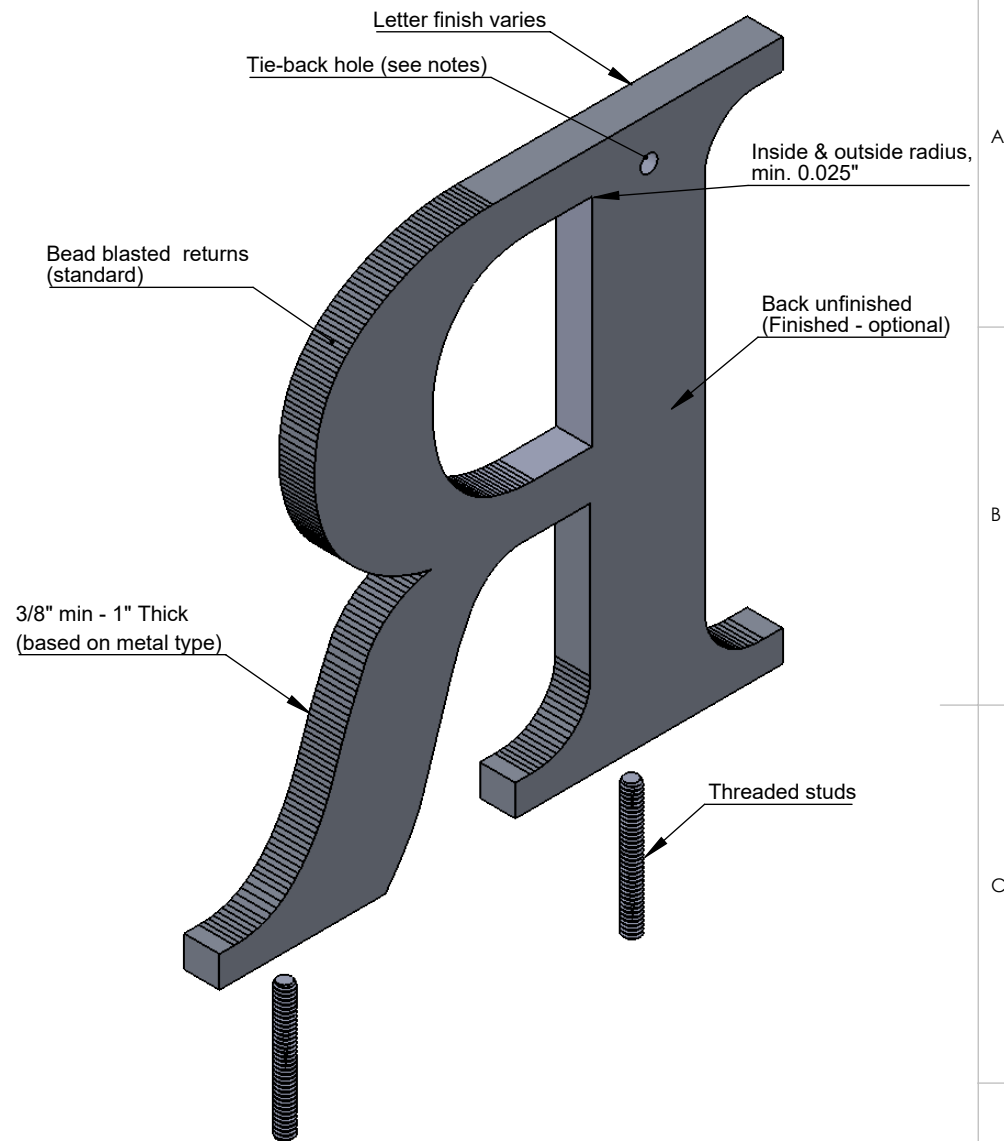

ISOMETRIC BACK VIEW II SCALE 1:1.5

TITLE: **FLAT CUT METAL - BOTTOM STUD MOUNT**

MATERIAL: **METAL**

PRODUCT TYPE: **FLAT CUT METAL**