

PRODUCT CONSTRUCTION EXAMPLE

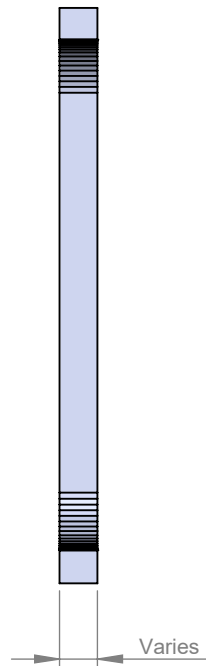

FRONT VIEW II SCALE 1:2



SECTION VIEW II SCALE 1:2

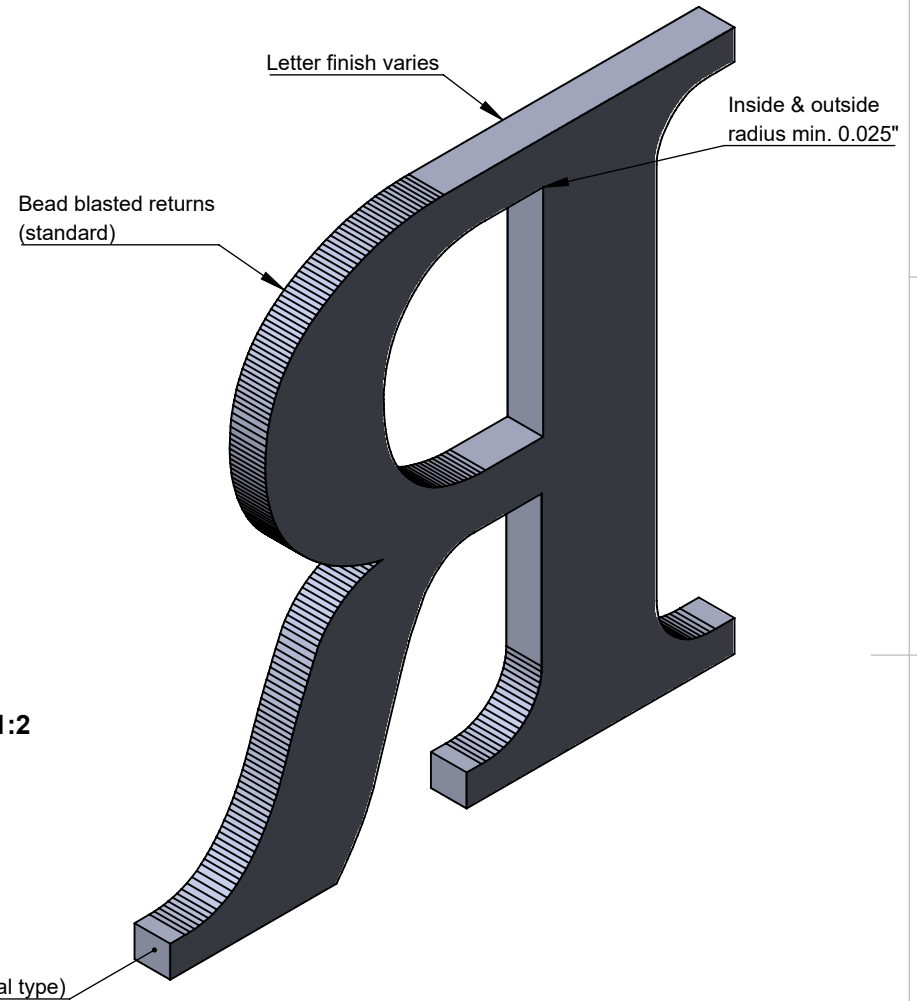

ISOMETRIC BACK VIEW II SCALE 1:1.5

NOTES:

- Optional - Back finished or unfinished
- Customer supplied install material
- Min. 1/8" stroke waterjet or lasercut based on gauge and material type
- Multiple face finish options
- Multiple gauges, based on metal
- Aluminum, stainless steel, brass, bronze, copper, corten
- Letters or logos, standard or custom
- 1/2" high and larger, based on metal & gauge



TITLE:

FLAT CUT METAL - PLAIN MOUNT

MATERIAL:

METAL

PRODUCT TYPE:

FLAT CUT METAL