

PRODUCT CONSTRUCTION EXAMPLE

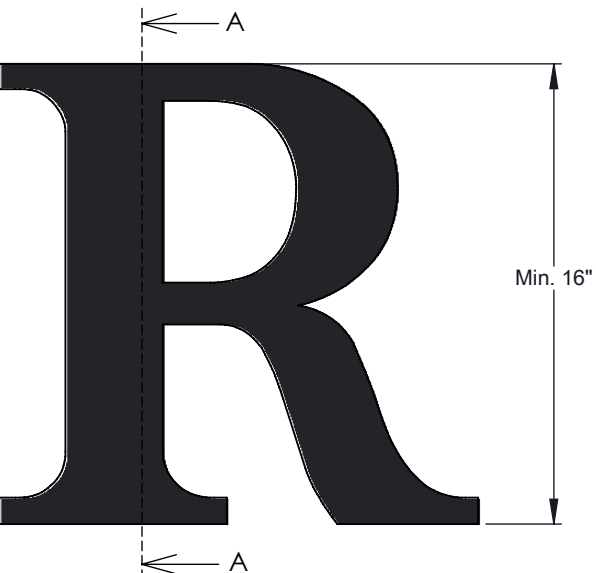

FRONT VIEW II SCALE 1:5

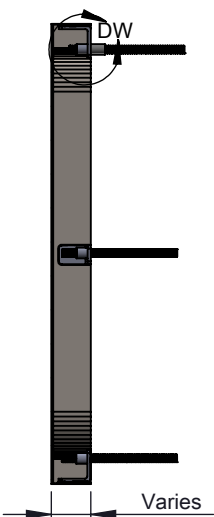

SECTION A-A II SCALE 1:5

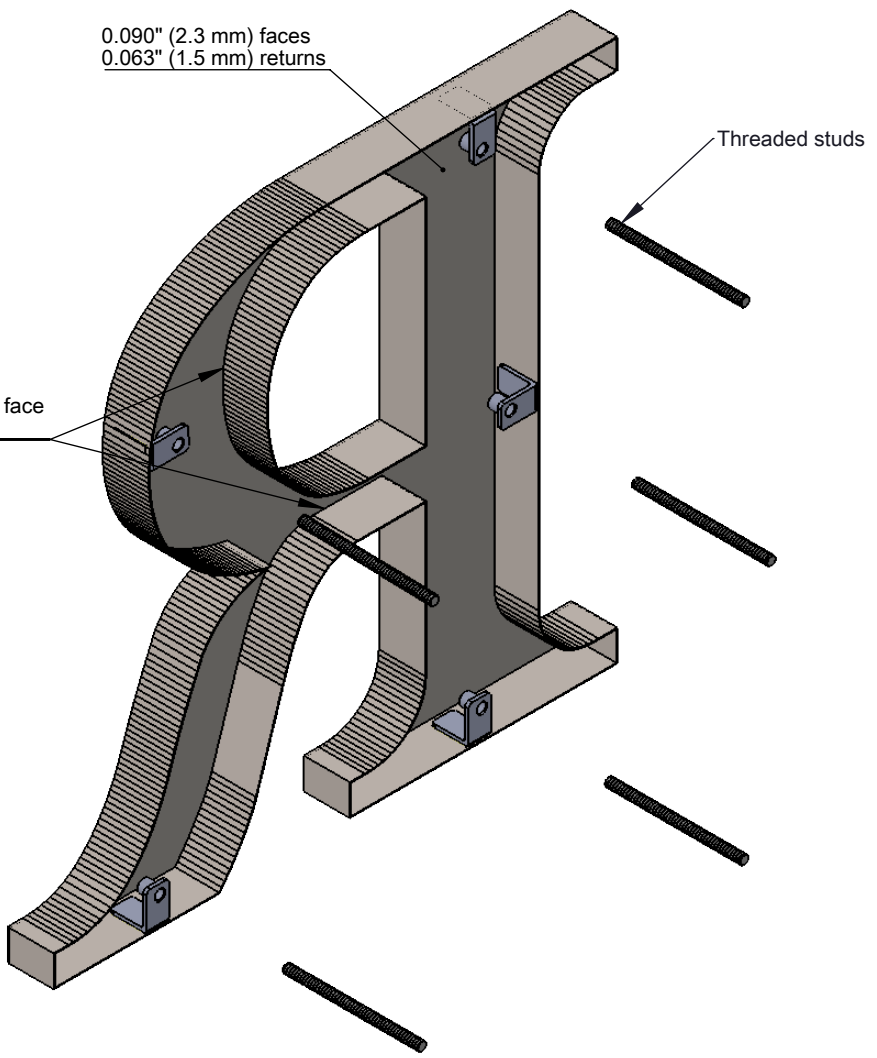

ISOMETRIC BACK VIEW II SCALE 1:3

"L" bracket secured with high resistance epoxy to return

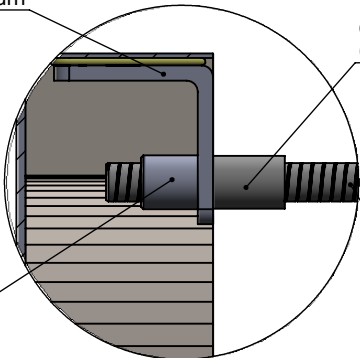

DETAIL DW II SCALE 1:1

Optional spacer sleeve (Size varies)

Aluminum mounting stud (Size varies (see table))

Threaded Stud Boss (Size varies by bracket)

LETTER SIZE	STUD BOSS
16" - 24"	10 - 24
over 24"	1/4 - 20

NOTES:  
- Return grain will run from face to back



TITLE: <b>METAL FACE NO BACK - SIDE MOUNT</b>	
MATERIAL: <b>5052 ALUMINUM ALLOY</b>	PRODUCT TYPE: <b>FABRICATED METAL</b>
DWG No. FAB20	REV. 03.23.22
SCALE: AS INDICATED	SHEET 1 OF 1